

1

Run a few sheets of blank paper through the printer to warm it up to operating temperature. Select normal print quality and gradually increase the paper weight setting until the toner fuses well and the image does not smudge*
Print on the blank side of the transfer paper, one sheet at a time using a bypass tray if possible
(there is no need to mirror your image or artwork)

*You may have to use a slow paper setting e.g. heavy paper, transparency or label mode. If in doubt, consult your printer manufacturer.

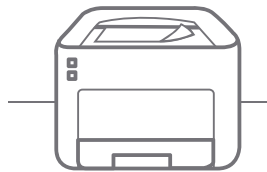
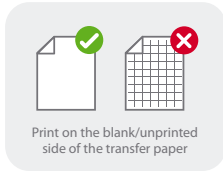

2

Trim around or contour cut the image
Note: This paper has a white film background



SILHOUETTE
BLADE SETTING*

SPEED 3 THICKNESS 1-2

*Adjust as necessary. Use a cutting mat (carrier sheet) and cut through the film layer only

3

Peel off backing paper



4

Prepare the heat press at 175°C / 350°F



5

Place image face up on substrate and cover with a Teflon or silicone sheet

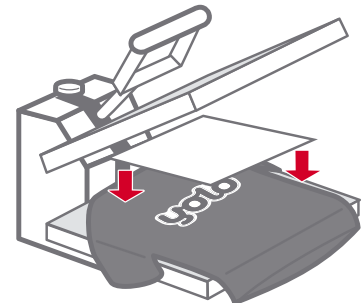

6

Apply **medium** pressure for 20-30 seconds

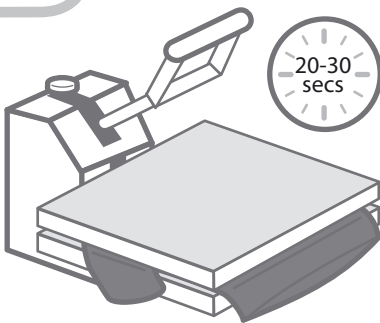

7



yolo tip

Repressing for 5-7 seconds with a Teflon or silicone sheet (remove when cold) to improve adhesion and increase softness and durability

wash and care instructions



Machine wash separately



Dry at low heat setting



Do not dry clean, bleach or directly iron transfer

contact

hello@yolo.co.uk

+44 (0) 2082 400 658

www.yolo.co.uk

Product code: LAS1

Store in a cool, dry place and seal the packaging between uses

Printed on 100% recycled paper